

ALUMINUM

Project Fact Sheet

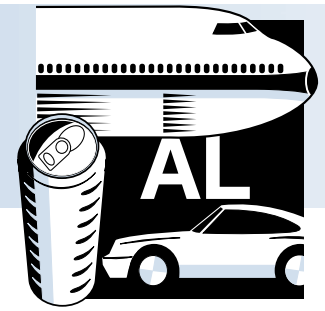

COOLANT CHARACTERISTICS

BENEFITS

The potential benefits of this technology include reducing annual remelting and recasting of ingot by 262 million pounds and reducing ingot cracking from three percent to one and a half percent. The estimated annual cost, energy, and environmental savings to the domestic aluminum industry from successful development and implementation of this technology could potentially be:

- \$13 million or \$0.125 per pound of product net shipments.
- 400 million Btu of energy savings per year.
- A reduction of up to 17 million pounds of CO₂, 6 million pounds of CO, and 21 million pounds of solid waste.

APPLICATIONS

Approximately 68% of the aluminum produced in the United States is cast into ingot prior to processing into sheet, plate, extrusions, or foil. The direct chill (DC) semicontinuous casting process is the primary process used. Researching coolant behavior will have a positive impact on and is expected to be of great value to the aluminum industry.



COOLANT CHARACTERISTICS AND CONTROL IN DIRECT CHILL (DC) CASTINGS OF ALUMINUM

Direct Chill (DC) casting is a critical process in the production of aluminum ingots. It is a casting process in which water-cooled molds initiate the first part of solidification. Thereafter, water sprays impinge on the shell of solid aluminum enclosing the liquid core. To obtain higher productivity and better quality products, it is important to precisely control the cooling rate in DC casting. Current methods of controlling the ingot cooling rate are empirical. A theoretical model based on system parameters and coolant characteristics has not been established. The cooling rate has a strong influence on the temperature, strain, and stress field in the cast product. A higher cooling rate can lead to higher thermal stresses and strains causing hot tearing and ingot cracking.

This project focuses on understanding the fundamentals of coolant behavior and developing strategies to control the cooling rate of DC casting of aluminum ingots. Project partners will conduct a fundamental study to identify various parameters affecting critical heat flux and boiling transition and evaluate the effects of various additives (impurity particulates, sodium and calcium salts, carbonates, bicarbonates, surfactants, etc.). Partners will also study the effect of water quality on the ingot-cracking tendency. The research results are expected to guide cooling strategies, which can then control metallurgical characteristics and mechanical properties. This will result in better ingot yield from existing DC casting practices.

DIRECT CHILL CASTING

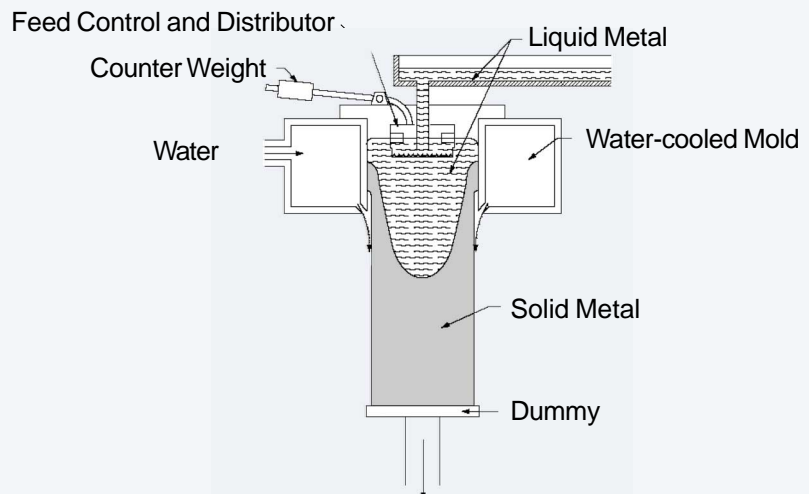

Direct chill casting process.

Project Description

Goals: The goals of this project are to understand the fundamentals of coolant behavior and develop strategies to control the quenching rate of DC casting of aluminum. By understanding the coolant characteristics, the parameters that control quenching can be manipulated to obtain the desired cooling rate. The purpose of an improved cooling system is to achieve higher quality mechanical and metallurgical properties. Project results will provide general guidelines for making appropriate changes in an aluminum caster. Reducing the need to remelt aluminum for desired product quality will result in energy savings and environmental benefits.

Progress and Milestones

Successful development of this technology will require each project partner to perform work appropriate to their expertise.

Idaho National Engineering and Environmental Laboratory (INEEL)

- Determine the boiling transition criteria related to quenching conditions.
 - Develop a correlation for critical heat flux at quenching conditions.
 - Develop boiling transition criteria from nucleate to film boiling.
- Define rewetting criteria by studying the conditions that will lead to rewetting of the hot metal surface.
 - Identify all the quenching parameters affecting dryout and rewetting of the solidified aluminum surface.
 - Develop a rewetting criterion that can define the conditions for rewetting, which may lead to the boiling transition.

Alcoa Incorporated

- Determine the effect of quenchant quality on the cracking of high-strength alloys.
- Determine ingot-to-coolant heat transfer rate and film-to-nucleate boiling transition.

University of California - Berkeley

- Examine the boiling of quenchants with various quenchant parameters. Then examine the effect of these additives on the boiling transitions.
- Model the effects of additives on interfacial stability during film and transition boiling.

Commercialization Plan

The research performed for this project is directly applicable to the direct chill casting process. INEEL and Alcoa signed a Cooperative Research and Development Agreement (CRADA). Any invention or patent produced under the CRADA can be used commercially by Alcoa. After a predetermined grace period, other private companies will also be able to use the same technology with a licensing agreement with either INEEL or Alcoa or both, depending on the situation. Research performed by the University of California - Berkeley is publicly available.



PROJECT PARTNERS

Idaho National Engineering and
Environmental Laboratory
Idaho Falls, ID

Alcoa Incorporated
Pittsburgh, PA

University of California - Berkeley
Berkeley, CA

FOR ADDITIONAL INFORMATION, PLEASE CONTACT:

Project Information

Manohar S. Sohal
Idaho National Engineering and
Environmental Laboratory
Phone: (208) 526-9412
Fax: (208) 526-8883
sohalsm@inel.gov

Aluminum Program

Simon Friedrich
Office of Industrial Technologies
Phone: (202) 586-6759
Fax: (202) 586-1658
simon.friedrich@ee.doe.gov

Please send any comments,
questions, or suggestions to
webmaster.oit@ee.doe.gov.

Visit our home page at
www.oit.doe.gov/aluminum

Office of Industrial Technologies
Energy Efficiency
and Renewable Energy
U.S. Department of Energy
Washington, D.C. 20585



July 2001