

FINAL
PENN RUN
WATERSHED TMDL
Indiana County

For Acid Mine Drainage Affected Segments



Prepared by:

Pennsylvania Department of Environmental Protection

June 28, 2006

TABLE OF CONTENTS

Introduction..... 3
Directions to the Penn Run Watershed 3
Hydrology 4
Segments addressed in this TMDL..... 4
Clean Water Act Requirements 4
Section 303(d) Listing Process 5
Basic Steps for Determining a TMDL..... 6
Watershed History 6
AMD Methodology..... 6
TMDL Endpoints..... 9
Other Inorganics 9
TMDL Elements (WLA, LA, MOS) 10
Allocation Summary 10
Recommendations..... 14
Public Participation..... 15

TABLES

Table 1. 303(d) Sub-List..... 3
Table 2. Applicable Water Quality Criteria..... 9
Table 3. TMDL Component Summary for the Penn Run Watershed..... 11

ATTACHMENTS

ATTACHMENT A..... 16
 Penn Run Watershed Map 16
ATTACHMENT B..... 21
 Method for Addressing Section 303(d) Listings for pH..... 21
ATTACHMENT C..... 24
 TMDLs By Segment..... 24
ATTACHMENT D..... 30
 Excerpts Justifying Changes Between the 1996, 1998, 2002 and 2004 Section 303(d) Lists.. 30
ATTACHMENT E..... 32
 Water Quality Data Used In TMDL Calculations 32
ATTACHMENT F..... 36
 Comment and Response..... 36

FINAL TMDL¹
Penn Run Watershed
Indiana County, Pennsylvania

Introduction

This report presents the Total Maximum Daily Loads (TMDLs) developed for segments in the Penn Run Watershed (Attachments A). These were done to address the impairments noted on the 1996 Pennsylvania Section 303(d) list of impaired waters, required under the Clean Water Act, and covers one segment on this list. All impairments resulted from acid drainage from abandoned coalmines. The TMDL addresses the three primary metals associated with acid mine drainage (iron, manganese, aluminum), sulfates and pH.

Table 1. 303(d) Sub-List								
State Water Plan (SWP) Subbasin: 18-D Two Lick Creek								
Year	Miles	Segment ID	DEP Stream Code	Stream Name	Designated Use	Data Source	Source	EPA 305(b) Cause Code
1996	2.4 1.4	5077	44276	Penn Run	CWF	305(b) Report	RE	Metals & Other Inorganics
1998	3.93	5077	44276	Penn Run	CWF	SWMP	AMD	Metals & Other Inorganics
2002	3.9	5077	44276	Penn Run	CWF	SWMP	AMD	Metals & Other Inorganics
2004	3.94	20040825-1200-RMS	44276	Penn Run	CWF	2004 Integrated List	AMD	Metals & Other Inorganics

Resource Extraction=RE
Cold Water Fishes = CWF
Surface Water Monitoring Program = SWMP
Abandoned Mine Drainage = AMD

See Attachment D, *Excerpts Justifying Changes Between the 1996, 1998, 2002 and 2004 Section 303(d) Lists*. The use designations for the stream segments in this TMDL can be found in PA Title 25 Chapter 93.

Directions to the Penn Run Watershed

The Penn Run Watershed is located in Western Pennsylvania, occupying an eastern central portion of Indiana County in Cherryhill Township. The watershed area is found on portions of the United States Geological Survey Brush Valley, Clymer, Commodore, and Strongtown 7.5-Minute Quadrangles. The area within the watershed consists of 7.6 square miles. Land uses

¹ Pennsylvania's 1996, 1998, 2002 and 2004 Section 303(d) lists were approved by the Environmental Protection Agency (EPA). The 1996 Section 303(d) list provides the basis for measuring progress under the 1997 lawsuit settlement of *American Littoral Society and Public Interest Group of Pennsylvania v. EPA*.

within the watershed include abandoned mine lands, forestlands, and rural residential properties with small communities scattered throughout the area.

Penn Run flows from the east into Two Lick Creek just upstream of the Two Lick Reservoir. The headwaters of Penn Run are just to the east of the village of Penn Run. Penn Run is located approximately 10 miles east of the Borough of Indiana, which is located in the center of Indiana County. To reach Penn Run, take Route 422 East from Indiana. Take the exit for Route 553 into the village of Penn Run. Route 553 crosses over Penn Run just north of the village of Penn Run.

Hydrology

The streams in the watershed develop in higher elevations in the east and flow westerly to discharge into Two Lick Creek, which is a tributary of Blacklick Creek. Penn Run originates near the village of Penn Run and flows north for approximately 2 ½ miles. The final stem of Penn Run is oriented in an east to west direction to its confluence with Two Lick Creek. The headwaters flow from elevations between 1500 and 1600 feet MSL to an elevation of 1200 MSL at the mouth.

Segments addressed in this TMDL

There are no active mining operations in the Penn Run Watershed. All of the discharges in the watershed are from abandoned mines and will be treated as non-point sources. Each segment on the Section 303(d) list is addressed as a separate TMDL. These TMDLs are expressed as long-term, average loadings. Due to the nature and complexity of mining effects on the watershed, expressing the TMDL as a long-term average gives a better representation of the data used for the calculations. See Attachment C for TMDL calculations.

Clean Water Act Requirements

Section 303(d) of the 1972 Clean Water Act requires states, territories, and authorized tribes to establish water quality standards. The water quality standards identify the uses for each waterbody and the scientific criteria needed to support that use. Uses can include designations for drinking water supply, contact recreation (swimming), and aquatic life support. Minimum goals set by the Clean Water Act require that all waters be “fishable” and “swimmable.”

Additionally, the federal Clean Water Act and the Environmental Protection Agency’s (EPA) implementing regulations (40 CFR Part 130) require:

- States to develop lists of impaired waters for which current pollution controls are not stringent enough to meet water quality standards (the list is used to determine which streams need TMDLs);
- States to establish priority rankings for waters on the lists based on severity of pollution and the designated use of the waterbody; states must also identify those waters for which TMDLs will be developed and a schedule for development;

- States to submit the list of waters to EPA every two years (April 1 of the even numbered years);
- States to develop TMDLs, specifying a pollutant budget that meets state water quality standards and allocate pollutant loads among pollution sources in a watershed, e.g., point and nonpoint sources; and
- EPA to approve or disapprove state lists and TMDLs within 30 days of final submission.

Despite these requirements, states, territories, authorized tribes, and EPA had not developed many TMDLs. Beginning in 1986, organizations in many states filed lawsuits against the EPA for failing to meet the TMDL requirements contained in the federal Clean Water Act and its implementing regulations. While EPA has entered into consent agreements with the plaintiffs in several states, other lawsuits still are pending across the country.

In the cases that have been settled to date, the consent agreements require EPA to backstop TMDL development, track TMDL development, review state monitoring programs, and fund studies on issues of concern (e.g., AMD, implementation of nonpoint source Best Management Practices (BMPs), etc.).

These TMDLs were developed in partial fulfillment of the 1997 lawsuit settlement of *American Littoral Society and Public Interest Group of Pennsylvania v. EPA*.

Section 303(d) Listing Process

Prior to developing TMDLs for specific waterbodies, there must be sufficient data available to assess which streams are impaired and should be on the Section 303(d) list. With guidance from the EPA, the states have developed methods for assessing the waters within their respective jurisdictions.

The primary method adopted by the Pennsylvania Department of Environmental Protection (DEP) for evaluating waters changed between the publication of the 1996 and 1998 Section 303(d) lists. Prior to 1998, data used to list streams were in a variety of formats, collected under differing protocols. Information also was gathered through the Section 305(b)² reporting process. DEP is now using the Statewide Surface Waters Assessment Protocol (SSWAP), a modification of the EPA's 1989 Rapid Bioassessment Protocol II (RBP-II), as the primary mechanism to assess Pennsylvania's waters. The SSWAP provides a more consistent approach to assessing Pennsylvania's streams.

The assessment method requires selecting representative stream segments based on factors such as surrounding land uses, stream characteristics, surface geology, and point source discharge locations. The biologist selects as many sites as necessary to establish an accurate assessment for a stream segment; the length of the assessed stream segment can vary between sites. All the

² Section 305(b) of the Clean Water Act requires a biannual description of the water quality of the waters of the state.

biological surveys included kick-screen sampling of benthic macroinvertebrates and habitat evaluations. Benthic macroinvertebrates are identified to the family level in the field.

After the survey is completed, the biologist determines the status of the stream segment. The decision is based on habitat scores and a series of narrative biological statements used to evaluate the benthic macroinvertebrate community. If the stream is determined to be impaired, the source and cause of the impairment is documented. An impaired stream must be listed on the state's Section 303(d) list with the source and cause. A TMDL must be developed for the stream segment and each pollutant. In order for the process to be more effective, adjoining stream segments with the same source and cause listing are addressed collectively, and on a watershed basis.

Basic Steps for Determining a TMDL

Although all watersheds must be handled on a case-by-case basis when developing TMDLs, there are basic processes or steps that apply to all cases. They include:

1. Collection and summarization of pre-existing data (watershed characterization, inventory contaminant sources, determination of pollutant loads, etc.);
2. Calculating the TMDL for the waterbody using EPA approved methods and computer models;
3. Allocating pollutant loads to various sources;
4. Determining critical and seasonal conditions;
5. Public review and comment and comment period on draft TMDL;
6. Submittal of final TMDL; and
7. EPA approval of the TMDL.

Watershed History

The Penn Run Watershed has been sporadically mined since the 1920's. Only a few small deep mines were operated between 1920 and 1960. Both surface and deep mining activities increased in the 1960's with the advent of new mining technologies and depletion of other mineral resources in the general area. Currently, there are no active coal mining operations in the watershed.

AMD Methodology

A two-step approach is used for the TMDL analysis of AMD impaired stream segments. The first step uses a statistical method for determining the allowable instream concentration at the point of interest necessary to meet water quality standards. This is done at each point of interest (sample point) in the watershed. The second step is a mass balance of the loads as they pass through the watershed. Loads at these points will be computed based on average annual flow.

The statistical analysis described below can be applied to situations where all of the pollutant loading is from non-point sources as well as those where there are both point and non-point sources. The following defines what are considered point sources and non-point sources for the purposes of our evaluation; point sources are defined as permitted discharges or a discharge that

has a responsible party, non-point sources are then any pollution sources that are not point sources. For situations where all of the impact is due to non-point sources, the equations shown below are applied using data for a point in the stream. The load allocation made at that point will be for all of the watershed area that is above that point. For situations where there are point-source impacts alone, or in combination with non-point sources, the evaluation will use the point-source data and perform a mass balance with the receiving water to determine the impact of the point source.

Allowable loads are determined for each point of interest using Monte Carlo simulation. Monte Carlo simulation is an analytical method meant to imitate real-life systems, especially when other analyses are too mathematically complex or too difficult to reproduce. Monte Carlo simulation calculates multiple scenarios of a model by repeatedly sampling values from the probability distribution of the uncertain variables and using those values to populate a larger data set. Allocations were applied uniformly for the watershed area specified for each allocation point. For each source and pollutant, it was assumed that the observed data were log-normally distributed. Each pollutant source was evaluated separately using @Risk³ by performing 5,000 iterations to determine the required percent reduction so that the water quality criteria, as defined in the *Pennsylvania Code, Title 25 Environmental Protection, Department of Environmental Protection, Chapter 93, Water Quality Standards*, will be met instream at least 99 percent of the time. For each iteration, the required percent reduction is:

$$PR = \text{maximum } \{0, (1 - Cc/Cd)\} \text{ where} \tag{1}$$

PR = required percent reduction for the current iteration

Cc = criterion in mg/l

Cd = randomly generated pollutant source concentration in mg/l based on the observed data

$$Cd = \text{RiskLognorm}(\text{Mean}, \text{Standard Deviation}) \text{ where} \tag{1a}$$

Mean = average observed concentration

Standard Deviation = standard deviation of observed data

The overall percent reduction required is the 99th percentile value of the probability distribution generated by the 5,000 iterations, so that the allowable long-term average (LTA) concentration is:

$$LTA = \text{Mean} * (1 - PR_{99}) \text{ where} \tag{2}$$

LTA = allowable LTA source concentration in mg/l

³@Risk – Risk Analysis and Simulation Add-in for Microsoft Excel, Palisade Corporation, Newfield, NY, 1990-1997.

Once the allowable concentration and load for each pollutant is determined, mass-balance accounting is performed starting at the top of the watershed and working down in sequence. This mass-balance or load tracking is explained below.

Load tracking through the watershed utilizes the change in measured loads from sample location to sample location, as well as the allowable load that was determined at each point using the @Risk program.

There are two basic rules that are applied in load tracking; rule one is that if the sum of the measured loads that directly affect the downstream sample point is less than the measured load at the downstream sample point it is indicative that there is an increase in load between the points being evaluated, and this amount (the difference between the sum of the upstream and downstream loads) shall be added to the allowable load(s) coming from the upstream points to give a total load that is coming into the downstream point from all sources. The second rule is that if the sum of the measured loads from the upstream points is greater than the measured load at the downstream point this is indicative that there is a loss of instream load between the evaluation points, and the ratio of the decrease shall be applied to the load that is being tracked (allowable load(s)) from the upstream point.

Tracking loads through the watershed gives the best picture of how the pollutants are affecting the watershed based on the information that is available. The analysis is done to insure that water quality standards will be met at all points in the stream. The TMDL must be designed to meet standards at all points in the stream, and in completing the analysis, reductions that must be made to upstream points are considered to be accomplished when evaluating points that are lower in the watershed. Another key point is that the loads are being computed based on average annual flow and should not be taken out of the context for which they are intended, which is to depict how the pollutants affect the watershed and where the sources and sinks are located spatially in the watershed.

For pH TMDLs, acidity is compared to alkalinity as described in Attachment B. Each sample point used in the analysis of pH by this method must have measurements for total alkalinity and total acidity. Net alkalinity is alkalinity minus acidity, both in units of milligrams per liter (mg/l) CaCO₃. Statistical procedures are applied, using the average value for total alkalinity at that point as the target to specify a reduction in the acid concentration. By maintaining a net alkaline stream, the pH value will be in the range between six and eight. This method negates the need to specifically compute the pH value, which for streams affected by low pH from AMD may not be a true reflection of acidity. This method assures that Pennsylvania's standard for pH is met when the acid concentration reduction is met.

Information for the TMDL analysis performed using the methodology described above is contained in the "TMDLs by Segment" section of this report.

TMDL Endpoints

One of the major components of a TMDL is the establishment of an instream numeric endpoint, which is used to evaluate the attainment of applicable water quality. An instream numeric endpoint, therefore, represents the water quality goal that is to be achieved by implementing the load reductions specified in the TMDL. The endpoint allows for a comparison between observed instream conditions and conditions that are expected to restore designated uses. The endpoint is based on either the narrative or numeric criteria available in water quality standards.

Because most of the pollution sources in the watershed are nonpoint sources, the TMDLs' component makeup will be Load Allocations (LAs). All allocations will be specified as long-term average daily concentrations. These long-term average concentrations are expected to meet water-quality criteria 99% of the time as required in PA Title 25 Chapter 96.3(c). The following table shows the applicable water-quality criteria for the selected parameters.

Table 2. Applicable Water Quality Criteria

<i>Parameter</i>	<i>Criterion Value (mg/l)</i>	<i>Total Recoverable/Dissolved</i>
Aluminum (Al)	0.75	Total Recoverable
Iron (Fe)	1.50	30 day average; Total Recoverable
Manganese (Mn)	1.00	Total Recoverable
pH *	6.0-9.0	N/A
SO ₄	250	Total Recoverable

*The pH values shown will be used when applicable. In the case of freestone streams with little or no buffering capacity, the TMDL endpoint for pH will be the natural background water quality.

Other Inorganics

The cause of inorganic impairment as listed on the 1996 Section 303(d) list is sulfates. Due to Title 25 Chapter 96.3(d), which requires the criterion to be met at the point of potable water supply withdrawals, a TMDL to address sulfates is not necessary. The nearest potable water withdrawal to Penn Run occurs approximately 6 miles downstream of the mouth of Penn Run at the PA American Water Company Indiana Plant (PWSID 5320025) located on Two Lick Creek. A map illustrating the location of the water supply intake, sampling stations and the Penn Run Watershed is located in Attachment A.

In order to demonstrate that the sulfate criterion of 250 mg/L is not exceeded at the potable water withdrawal due to sulfates from Penn Run, a mass balance is used to calculate the sulfate concentration downstream of Penn Run. Sulfate data was available at point KBLTL3 on Two Lick Creek just upstream of Penn Run; however in-stream flow measurements were not available. Flow for this point was estimated using the unit-area hydrology from a known point, KBLTL2 on Two Lick Creek.

The watershed area above sample point KBLTL3 is approximately 55 square miles. The known flow point on Two Lick Creek had an average flow of 122.9 MGD, and a watershed area of 170 square miles. This gives a flow yield of 0.72 MGD/sq. mi. Multiplying the flow yield for the

known point times the watershed area above point KBLTL3 equals a flow of 39.8 MGD at sample point KBLTL3.

Solving the mass balance equation using the 99th percentile sulfate value of each data set, the calculated downstream sulfate concentration is 254 mg/L. Although this is greater than the criterion of 250 mg/L, this is the concentration just downstream of the mouth of Penn Run. It is expected that the criterion will not be exceeded at the water supply intake, which is 6 miles downstream. The average sulfate concentration at point KBLTL2 downstream of the water supply intake is 97.4 mg/L and at KBLTL3 upstream of Penn Run it is 154.7 mg/L. This demonstrates that the sulfate concentration from upstream of Penn Run to downstream of the water supply intake is decreasing.

Mass Balance:

$$C_d * Q_d = (C_u * Q_u) + (C_{pr} * Q_{pr})$$

Solving for C_d , where:

C_d = Downstream Concentration

Q_d = Downstream Flow = 46.9 MGD

C_u = 99th Percentile Upstream Concentration = 219 mg/L

Q_u = Upstream Flow = 39.8 MGD

C_{pr} = Penn Run 99th Percentile Concentration = 451 mg/L

Q_{pr} = Penn Run Flow = 7.1 MGD

All supporting data is located in Appendix E.

TMDL Elements (WLA, LA, MOS)

$$\text{TMDL} = \text{WLA} + \text{LA} + \text{MOS}$$

A TMDL equation consists of a waste load allocation (WLA), load allocation (LA), and a margin of safety (MOS). The waste load allocation is the portion of the load assigned to point sources. The load allocation is the portion of the load assigned to non-point sources. The margin of safety is applied to account for uncertainties in the computational process. The margin of safety may be expressed implicitly (documenting conservative processes in the computations) or explicitly (setting aside a portion of the allowable load). The TMDL allocations in this report are based on available data. Other allocation schemes could also meet the TMDL.

Allocation Summary

These TMDLs will focus remediation efforts on the identified numerical reduction targets for each watershed. The reduction schemes in Table 3 for each segment are based on the assumption that all upstream allocations are achieved and take into account all upstream reductions. Attachment C contains the TMDLs by segment analysis for each allocation point in a detailed discussion. As changes occur in the watershed, the TMDLs may be re-evaluated to

reflect current conditions. An implicit MOS based on conservative assumptions in the analysis is included in the TMDL calculations.

The allowable LTA concentration in each segment is calculated using Monte Carlo Simulation as described previously. The allowable load is then determined by multiplying the allowable concentration by the flow and a conversion factor at each sample point. The allowable load is the TMDL.

Each permitted discharge in a segment is assigned a waste load allocation and the total waste load allocation for each segment is included in this table. There are currently no permitted discharges in the Penn Run Watershed; therefore, all WLAs are zero. The LA at each point includes all loads entering the segment, including those from upstream allocation points. The percent reduction is calculated to show the amount of load that needs to be reduced within a segment in order for water quality standards to be met at the point.

In some instances, instream processes, such as settling, are taking place within a stream segment. These processes are evidenced by a decrease in measured loading between consecutive sample points. It is appropriate to account for these losses when tracking upstream loading through a segment. The calculated upstream load lost within a segment is proportional to the difference in the measured loading between the sampling points.

In the instance that the allowable load is equal to the existing load (e.g. manganese point MP1, Table 3), the simulation determined that water quality standards are being met instream 99% of the time and no TMDL is necessary for the parameter at that point. Although a TMDL is not necessary, the measured load is considered at the next downstream allocation point.

Table 3. TMDL Component Summary for the Penn Run Watershed

Station	Parameter	Existing Load (lbs/day)	TMDL Allowable Load (lbs/day)	WLA (lbs/day)	LA (lbs/day)	Load Reduction (lbs/day)	Percent Reduction %
MP1	<i>Penn Run, upstream of mining impacts</i>						
	Fe	8.0	7.3	0.0	7.3	0.7	9
	Mn	1.3	1.3	NA	NA	0.0	0
	Al	12.6	12.6	NA	NA	0.0	0
	Acidity	0.0	0.0	NA	NA	0.0	0
MP7	<i>Mouth of Unnamed Tributary 44281</i>						
	Fe	52.1	4.2	0.0	4.2	47.9	92
	Mn	21.5	5.0	0.0	5.0	16.5	77
	Al	28.3	1.7	0.0	1.7	26.6	94
	Acidity	442.6	48.7	0.0	48.7	393.9	89
MP13	<i>Mouth of Unnamed Tributary 44280</i>						
	Fe	30.8	0.9	0.0	0.9	29.9	97
	Mn	23.1	0.5	0.0	0.5	22.6	98
	Al	10.2	0.4	0.0	0.4	9.8	96
	Acidity	234.2	1.2	0.0	1.2	233.0	100

Station	Parameter	Existing Load (lbs/day)	TMDL Allowable Load (lbs/day)	WLA (lbs/day)	LA (lbs/day)	Load Reduction (lbs/day)	Percent Reduction %
MP14	<i>Mouth of Unnamed Tributary 44278</i>						
	Fe	1.8	1.8	NA	NA	0.0	0
	Mn	5.1	0.6	0.0	0.6	4.5	88
	Al	2.8	0.3	0.0	0.3	2.4	88
	Acidity	84.6	5.1	0.0	5.1	79.5	94
MP15	<i>Mouth of Penn Run</i>						
	Fe	327.5	29.5	0.0	29.5	219.5	88
	Mn	161.4	24.2	0.0	24.2	93.6	79
	Al	83.9	17.6	0.0	17.6	27.5	61
	Acidity	1,224.9	147.0	0.0	147.0	371.5	72

NA meets WQS. No TMDL necessary.

Following is an example of how the allocations, presented in Table 3 are calculated. For this example, manganese allocations are shown. As demonstrated in the example, all upstream contributing loads are accounted for at each point. Attachment C contains the TMDLs by segment analysis for each allocation point in a detailed discussion. These analyses follow the example. Attachment A contains a map of the sampling point locations for reference.

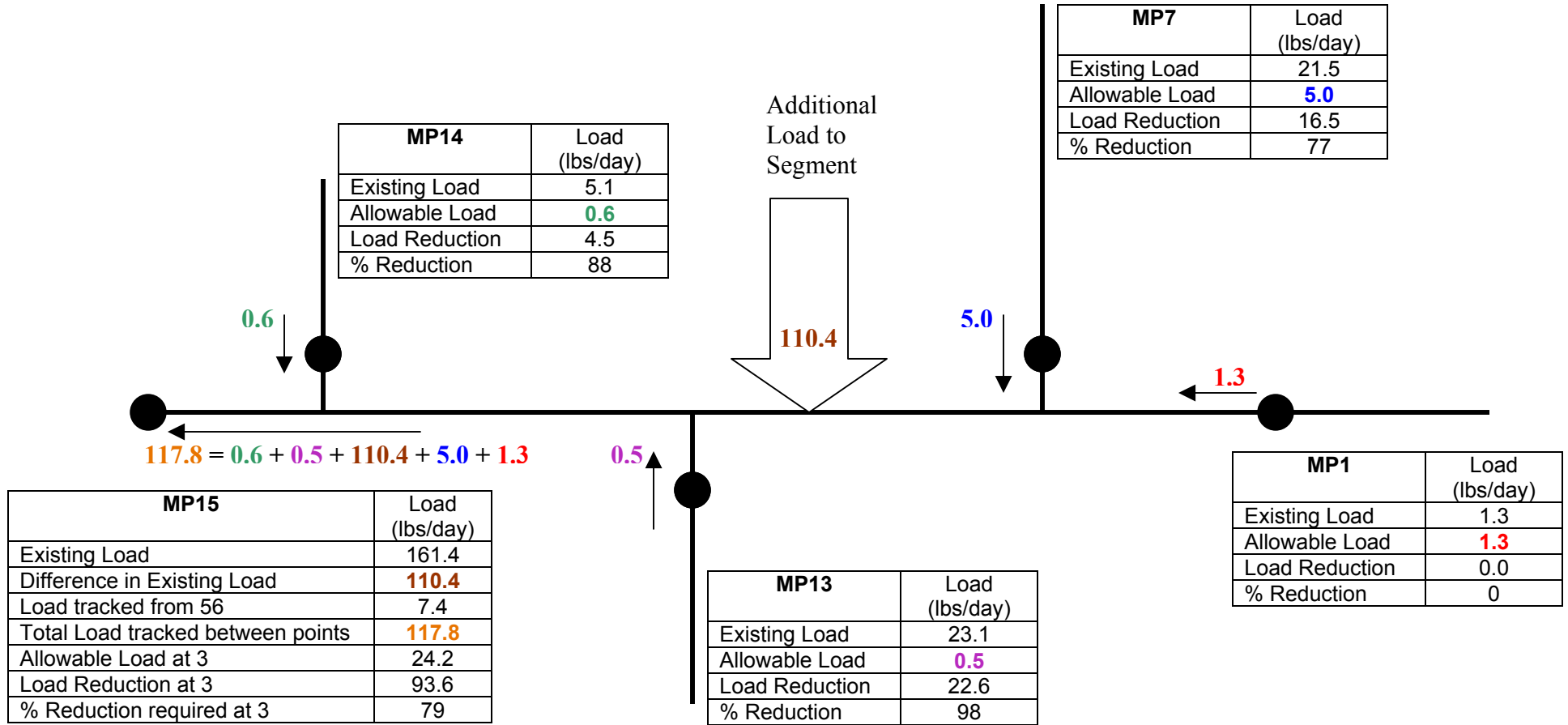

Recommendations

Currently there is a watershed assessment underway for the Kiski-Conemaugh drainage basin, which includes Blacklick Creek and its tributaries Two Lick Creek and Penn Run. All of the tributaries and sources of acid mine drainage will be evaluated and prioritized based on their severity and flow. The Kiski-Conemaugh Stream Team is an active watershed group and its efforts involve the Blacklick Creek Watershed Association. The group will use the watershed assessment to focus its attention on the top priorities for the watershed. Once the problem areas have been prioritized the group can then apply for funding to begin the process of cleaning up the watershed.

Two primary programs provide maintenance and improvement of water quality in the watershed. DEP's efforts to reclaim abandoned mine lands, coupled with its duties and responsibilities for issuing NPDES permits, will be the focal points in water quality improvement.

Additional opportunities for water quality improvement are both ongoing and anticipated. Historically, a great deal of research into mine drainage has been conducted by DEP's Bureau of Abandoned Mine Reclamation, which administers and oversees the Abandoned Mine Reclamation Program in Pennsylvania; the United States Office of Surface Mining; the National Mine Land Reclamation Center; the National Environmental Training Laboratory; and many other agencies and individuals. Funding from EPA's CWA Section 319(a) Grant program and Pennsylvania's Growing Greener program has been used extensively to remedy mine drainage impacts. These many activities are expected to continue and result in water quality improvement.

The DEP Bureau of Mining and Reclamation administers an environmental regulatory program for all mining activities, mine subsidence regulation, mine subsidence insurance, and coal refuse disposal; conducts a program to ensure safe underground bituminous mining and protect certain structures from subsidence; administers a mining license and permit program; administers a regulatory program for the use, storage, and handling of explosives; provides for training, examination, and certification of applicants for blaster's licenses; administers a loan program for bonding anthracite underground mines and for mine subsidence; and administers the EPA Watershed Assessment Grant Program, the Small Operator's Assistance Program (SOAP), and the Remining Operators Assistance Program (ROAP).

Mine reclamation and well plugging refers to the process of cleaning up environmental pollutants and safety hazards associated with a site and returning the land to a productive condition, similar to DEP's Brownfields program. Since the 1960's, Pennsylvania has been a national leader in establishing laws and regulations to ensure reclamation and plugging occur after active operation is completed.

Pennsylvania is striving for complete reclamation of its abandoned mines and plugging of its orphaned wells. Realizing this task is no small order, DEP has developed concepts to make abandoned mine reclamation easier. These concepts, collectively called Reclaim PA, include

legislative, policy land management initiatives designed to enhance mine operator, volunteer land DEP reclamation efforts. Reclaim PA has the following four objectives.

- To encourage private and public participation in abandoned mine reclamation efforts
- To improve reclamation efficiency through better communication between reclamation partners
- To increase reclamation by reducing remaining risks
- To maximize reclamation funding by expanding existing sources and exploring new sources.

Reclaim PA is DEP's initiative designed to maximize reclamation of the state's quarter million acres of abandoned mineral extraction lands. Abandoned mineral extraction lands in Pennsylvania constituted a significant public liability – more than 250,000 acres of abandoned surface mines, 2,400 miles of streams polluted with mine drainage, over 7,000 orphaned and abandoned oil and gas wells, widespread subsidence problems, numerous hazardous mine openings, mine fires, abandoned structures and affected water supplies – representing as much as one third of the total problem nationally.

Public Participation

Public notice of the draft TMDL was published in the *Pennsylvania Bulletin* on March 25, 2006 and the *Indiana Gazette*, Indiana, PA to foster public comment on the allowable loads calculated. The public comment period on this TMDL was open from March 16, 2006 to May 15, 2006. A public meeting was held on March 16, 2006 at the Robert Shaw Building Conference Room, Indiana University, Indiana, Pennsylvania, to discuss the proposed TMDL.

Attachment A



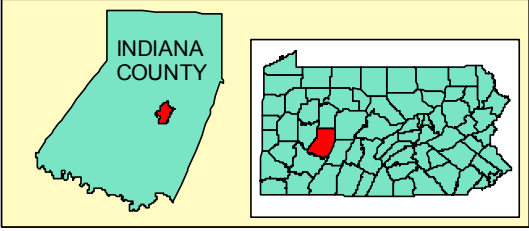
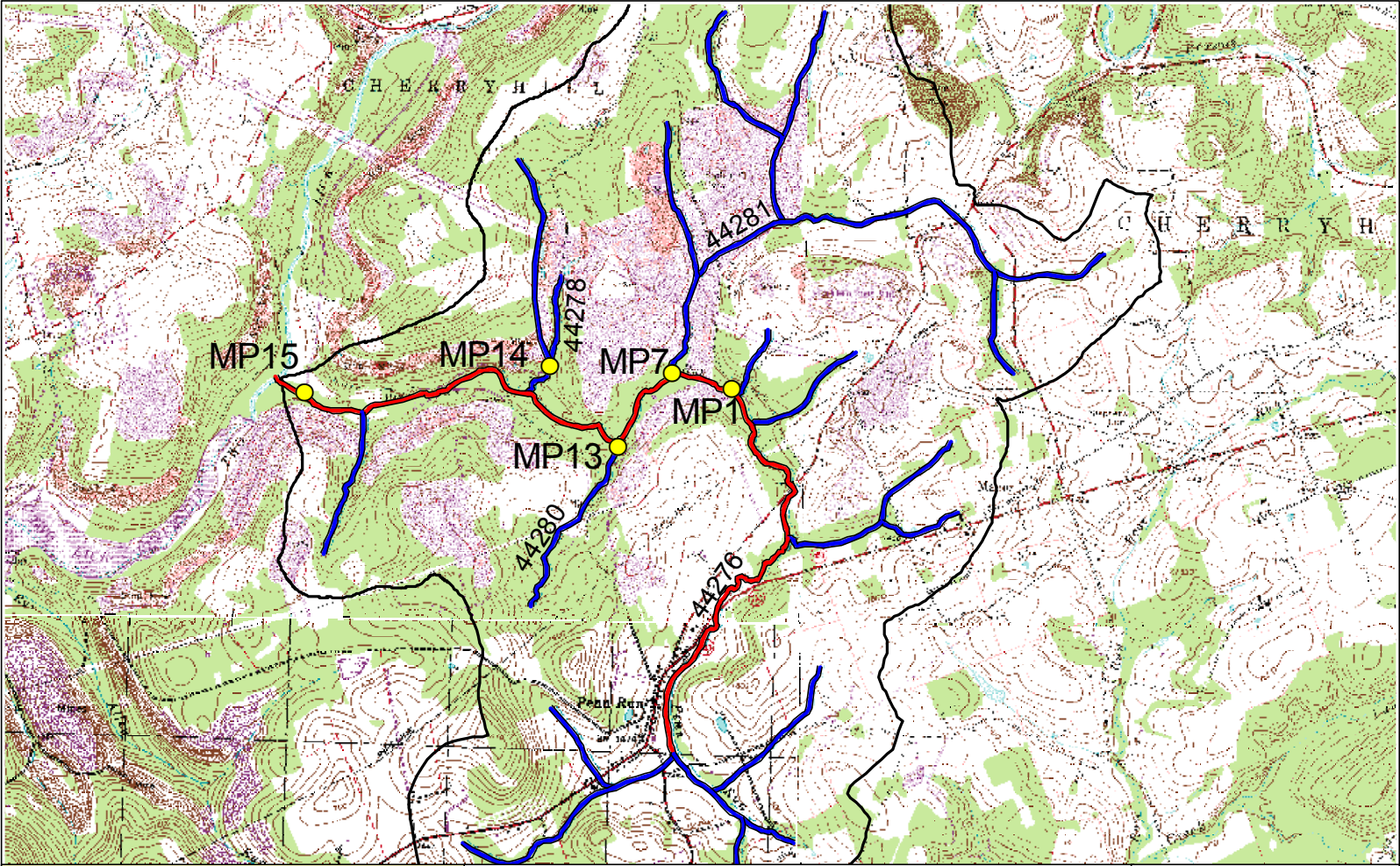

Penn Run Watershed Map



Penn Run Watershed



Legend

-  Sample Point
- Streams**
 -  Nonattaining
 -  Unassessed
-  Watershed Boundary

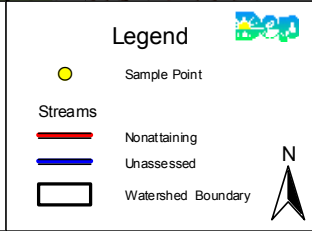
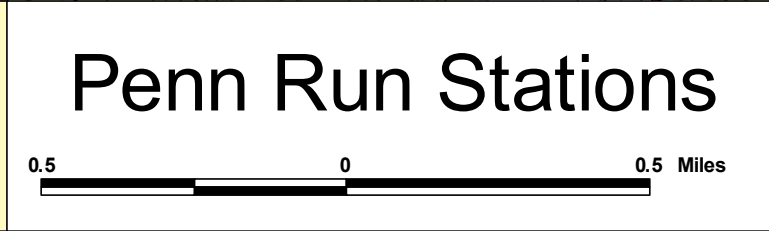
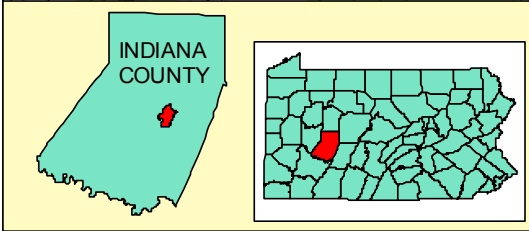
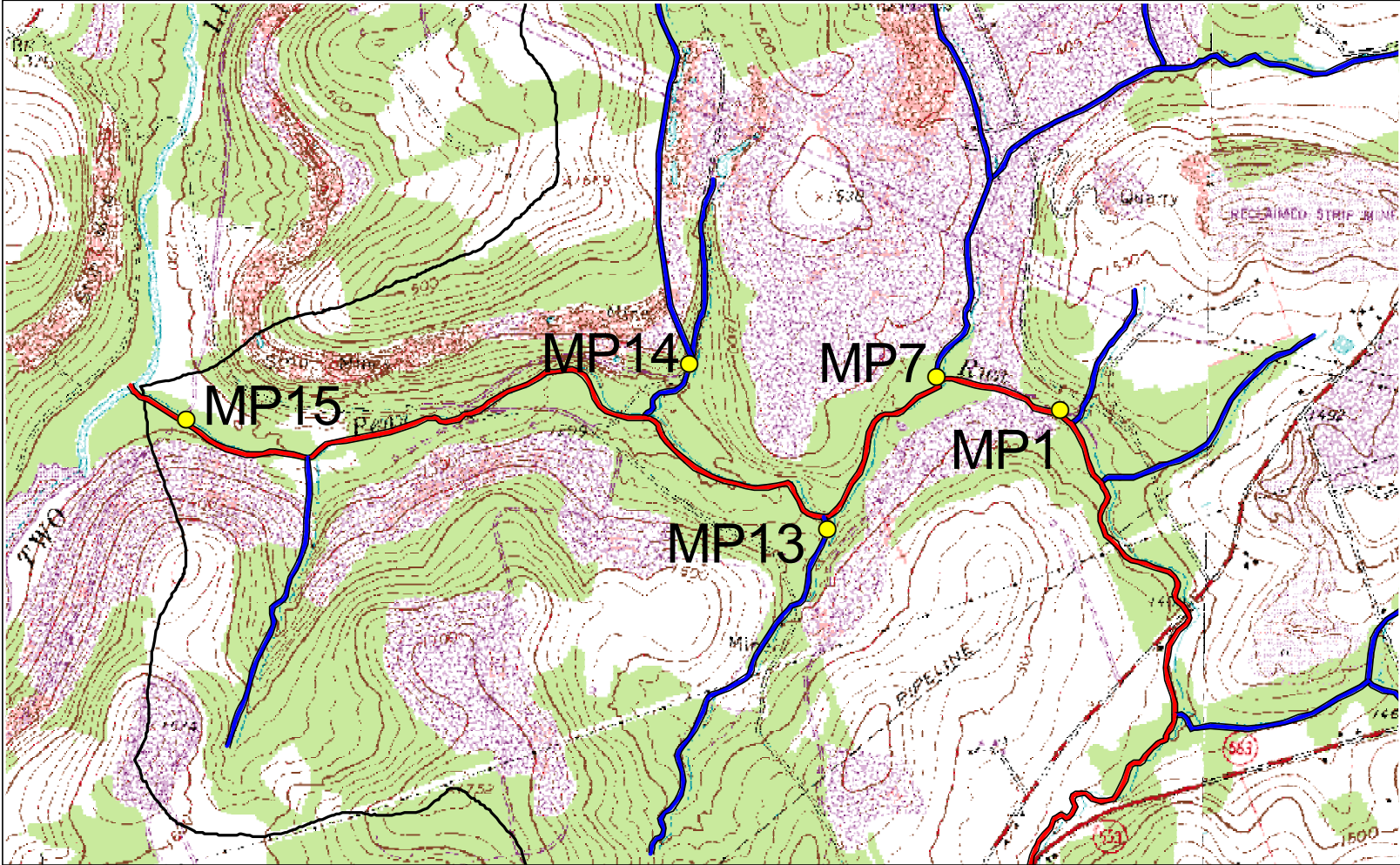

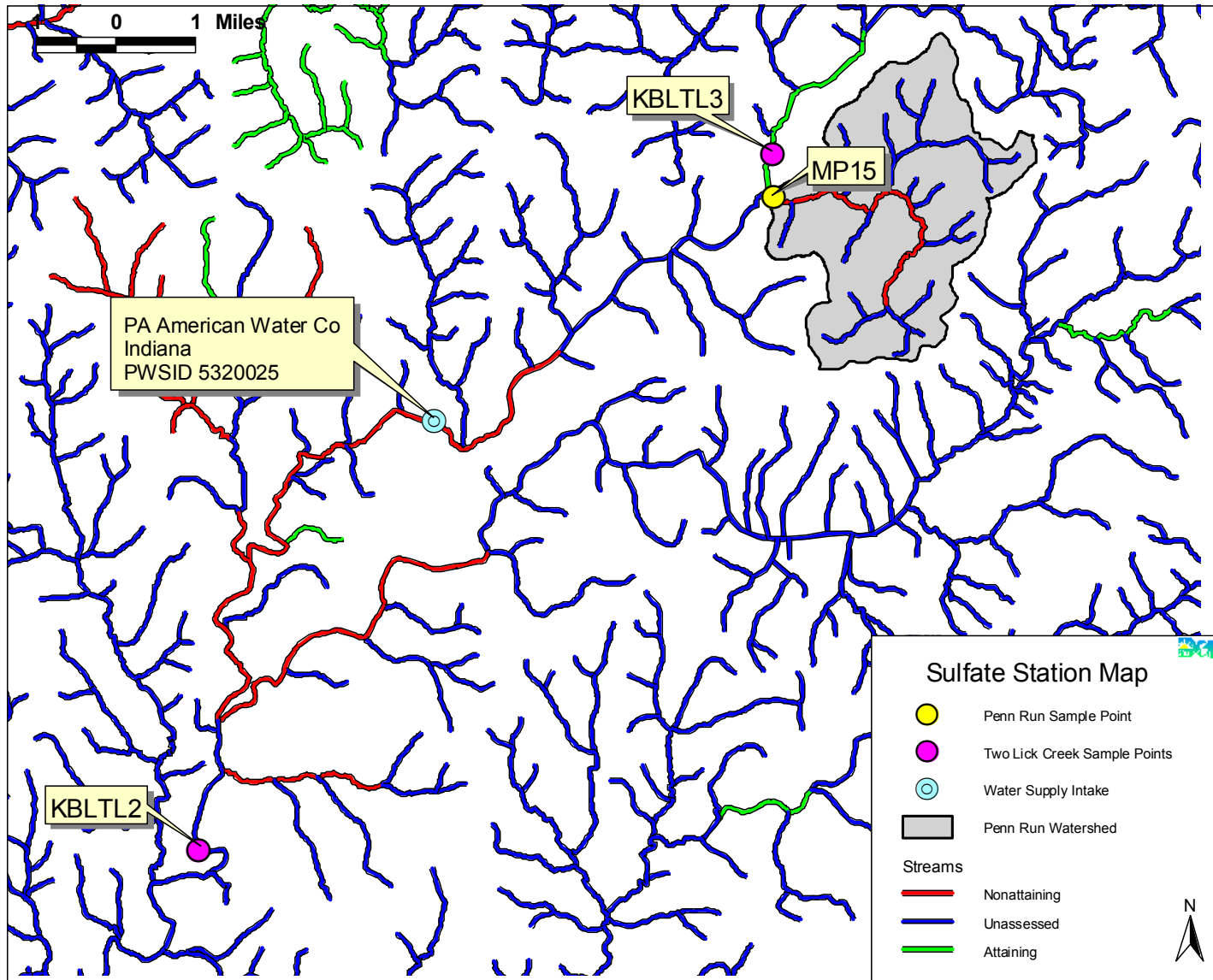

Penn Run Sampling Station Diagram

Arrows represent direction of flow

Diagram not to scale

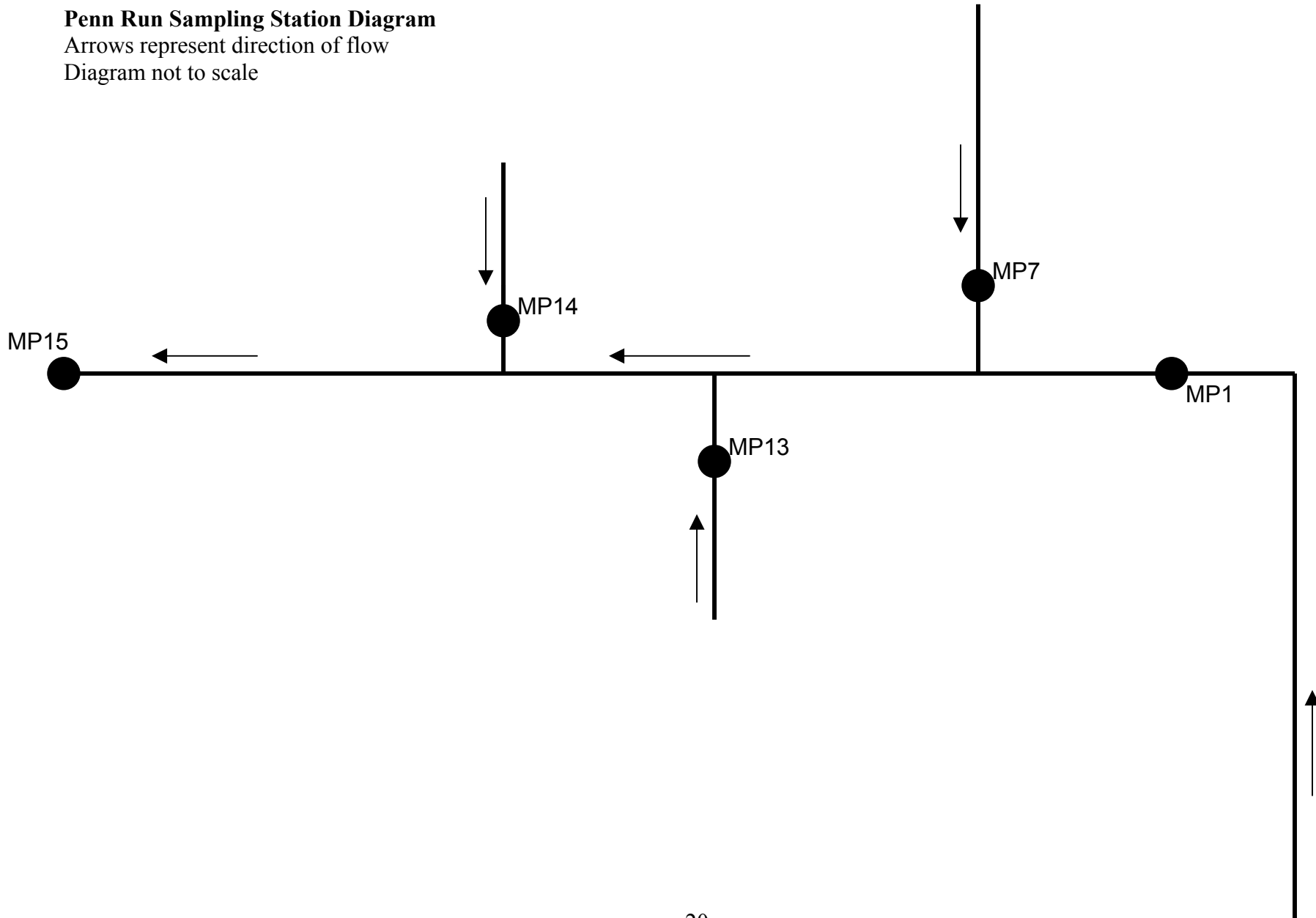

Attachment B

Method for Addressing Section 303(d) Listings for pH

Method for Addressing Section 303(d) Listings for pH

There has been a great deal of research conducted on the relationship between alkalinity, acidity, and pH. Research published by the Department of Environmental Protection demonstrates that by plotting net alkalinity (alkalinity-acidity) vs. pH for 794 mine sample points, the resulting pH value from a sample possessing a net alkalinity of zero is approximately equal to six (Figure 1). Where net alkalinity is positive (greater than or equal to zero), the pH range is most commonly six to eight, which is within the EPA's acceptable range of six to nine and meets Pennsylvania water quality criteria in Chapter 93.

The pH, a measurement of hydrogen ion acidity presented as a negative logarithm, is not conducive to standard statistics. Additionally, pH does not measure latent acidity. For this reason, and based on the above information, Pennsylvania is using the following approach to address the stream impairments noted on the Section 303(d) list due to pH. The concentration of acidity in a stream is at least partially chemically dependent upon metals. For this reason, it is extremely difficult to predict the exact pH values, which would result from treatment of abandoned mine drainage. Therefore, net alkalinity will be used to evaluate pH in these TMDL calculations. This methodology assures that the standard for pH will be met because net alkalinity is a measure of the reduction of acidity. When acidity in a stream is neutralized or is restored to natural levels, pH will be acceptable. Therefore, the measured instream alkalinity at the point of evaluation in the stream will serve as the goal for reducing total acidity at that point. The methodology that is applied for alkalinity (and therefore pH) is the same as that used for other parameters such as iron, aluminum, and manganese that have numeric water quality criteria.

Each sample point used in the analysis of pH by this method must have measurements for total alkalinity and total acidity. Net alkalinity is alkalinity minus acidity, both being in units of milligrams per liter (mg/l) CaCO₃. The same statistical procedures that have been described for use in the evaluation of the metals is applied, using the average value for total alkalinity at that point as the target to specify a reduction in the acid concentration. By maintaining a net alkaline stream, the pH value will be in the range between six and eight. This method negates the need to specifically compute the pH value, which for mine waters is not a true reflection of acidity. This method assures that Pennsylvania's standard for pH is met when the acid concentration reduction is met.

Reference: *Rose, Arthur W. and Charles A. Cravotta, III 1998. Geochemistry of Coal Mine Drainage. Chapter 1 in Coal Mine Drainage Prediction and Pollution Prevention in Pennsylvania. Pa. Dept. of Environmental Protection, Harrisburg, Pa.*

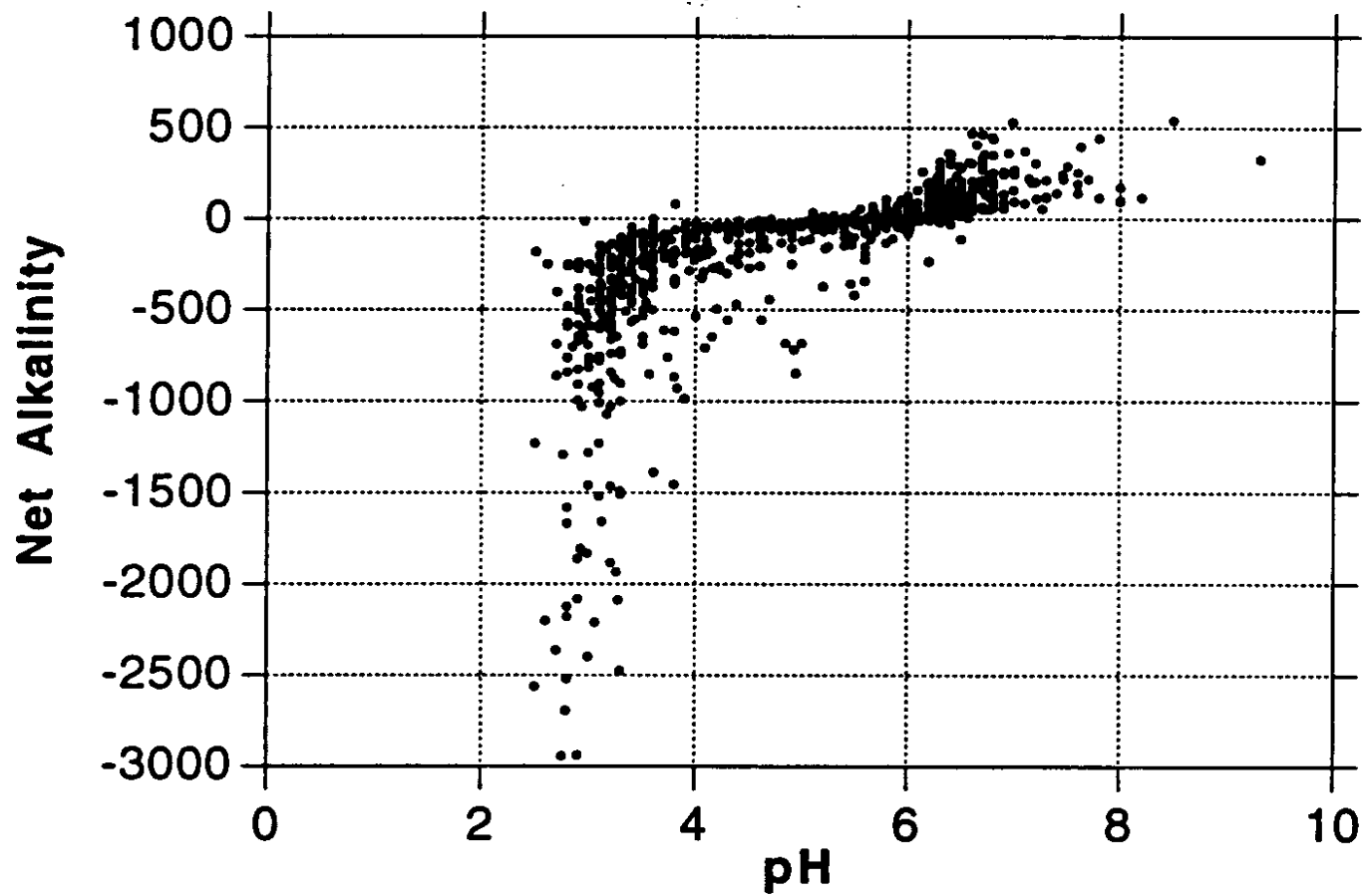

Figure 1. Net Alkalinity vs. pH. Taken from Figure 1.2 Graph C, pages 1-5, of Coal Mine Drainage Prediction and Pollution Prevention in Pennsylvania

Attachment C

TMDLs By Segment

Penn Run

The TMDL for Penn Run consists of load allocations of three tributaries and two sampling sites along the stream.

Penn Run is listed as impaired on the PA Section 303(d) list by high metals from AMD as being the cause of the degradation to the stream. The stream is not listed for pH impairments; however, data shows that the water quality standard is not met at all points; therefore, pH is addressed as part of the TMDL for Penn Run. The method and rationale for addressing pH is contained in Attachment B.

An allowable long-term average in-stream concentration was determined at each point for iron, manganese, aluminum, and acidity. The analysis is designed to produce an average value that, when met, will be protective of the water-quality criterion for that parameter 99% of the time. An analysis was performed using Monte Carlo simulation to determine the necessary long-term average concentration needed to attain water-quality criteria 99% of the time. The simulation was run assuming the data set was lognormally distributed. Using the mean and standard deviation of the data set, 5000 iterations of sampling were completed, and compared against the water-quality criterion for that parameter. For each sampling event a percent reduction was calculated, if necessary, to meet water-quality criteria. A second simulation that multiplied the percent reduction times the sampled value was run to insure that criteria were met 99% of the time. The mean value from this data set represents the long-term average concentration that needs to be met to achieve water-quality standards.

TMDL Calculations - Sample Point MP1, Penn Run upstream of mining impacts

The TMDL for sample point MP1 consists of a load allocation to all of the area above the point (Attachment A). The load allocation for this segment was computed using water-quality sample data collected at point MP1. The average flow of 2.04 MGD, measured at the point, is used for these computations.

This segment was included on the 1996 PA Section 303(d) list for metals impairments from AMD. Sample data at point MP1 shows pH ranging between 6.8 and 8.0; pH is not addressed as part of this TMDL.

Water quality analysis determined that the measured manganese and aluminum loads are equal to the allowable loads. Because WQS are met, TMDLs for manganese and aluminum are not necessary. Although TMDLs are not necessary, the measured loads are considered at the next downstream point, MP15.

All values for iron are below the criterion; however, water quality analysis determined a necessary reduction. Point MP1 is upstream of all mining impacts to Penn Run.

Parameter	Measured Sample Data		Allowable	
	Conc. (mg/l)	Load (lbs/day)	LTA Conc. (mg/l)	Load (lbs/day)
Al	0.74	2.6	0.74	12.6
Fe	0.47	8.01	0.43	7.3
Mn	0.08	1.3	0.08	1.3
Acidity	0.00	0.0	0.00	0.0
Alkalinity	79.37	1,352.2		

	Al (lbs/day)	Fe (lbs/day)	Mn (lbs/day)	Acidity (lbs/day)
Existing Load	12.6	8.0	1.3	0.0
Allowable Load	12.6	7.3	1.3	0.0
Load Reduction	0.0	0.7	0.0	0.0
% Reduction Required	0	9	0	0

TMDL Calculations - Sample Point MP7, Mouth of Unnamed Tributary 44281

The TMDL for sample point MP7 consists of a load allocation to all of the area above the point (Attachment A). The load allocation for this tributary was computed using water-quality sample data collected at point MP7. The average flow of 1.17 MGD, measured at the point, is used for these computations.

This segment is not included on the PA Section 303(d) list for impairments from AMD. Sample data at point MP7 shows pH ranging between 4.5 and 6.3; pH is addressed as part of this TMDL.

Parameter	Measured Sample Data		Allowable	
	Conc. (mg/l)	Load (lbs/day)	LTA Conc. (mg/l)	Load (lbs/day)
Al	2.90	28.3	0.17	1.7
Fe	5.34	52.1	0.43	4.2
Mn	2.21	21.5	0.51	5.0
Acidity	45.37	442.6	4.99	48.7
Alkalinity	11.94	116.5		

	Al (lbs/day)	Fe (lbs/day)	Mn (lbs/day)	Acidity (lbs/day)
Existing Load	28.3	52.1	21.5	442.6
Allowable Load	1.7	4.2	5.0	48.7
Load Reduction	26.6	47.9	16.5	393.9
% Reduction Required	94	92	77	89

TMDL Calculations - Sample Point MP13, Mouth of Unnamed Tributary 44280

The TMDL for sample point MP13 consists of a load allocation to all of the area above the point (Attachment A). The load allocation for this tributary was computed using water-quality sample data collected at point MP13. The average flow of 0.28 MGD, measured at the point, is used for these computations.

This segment is not included on the PA Section 303(d) list for impairments from AMD. Sample data at point MP13 shows pH ranging between 3.2 and 4.9; pH is addressed as part of this TMDL.

Parameter	Measured Sample Data		Allowable	
	Conc. (mg/l)	Load (lbs/day)	LTA Conc. (mg/l)	Load (lbs/day)
Al	4.35	10.2	0.17	0.4
Fe	13.14	30.8	0.39	0.9
Mn	9.83	23.1	0.20	0.5
Acidity	99.80	234.2	0.50	1.2
Alkalinity	1.77	4.2		

	Al (lbs/day)	Fe (lbs/day)	Mn (lbs/day)	Acidity (lbs/day)
Existing Load	10.2	30.8	23.1	234.2
Allowable Load	0.4	0.9	0.5	1.2
Load Reduction	9.8	29.9	22.6	233.0
% Reduction Required	96	97	98	99.5

TMDL Calculations - Sample Point MP14, Mouth of Unnamed Tributary 44278

The TMDL for sample point MP14 consists of a load allocation to all of the area above the point (Attachment A). The load allocation for this tributary was computed using water-quality sample data collected at point MP14. The average flow of 0.18 MGD, measured at the point, is used for these computations.

This segment is not included on the PA Section 303(d) list for impairments from AMD. Sample data at point MP13 shows pH ranging between 4.0 and 4.9; pH is addressed as part of this TMDL.

Water quality analysis determined the measured and allowable iron loading is equal. Because the WQS is met, a TMDL for iron is not necessary. Although a TMDL is not necessary, the iron load is considered at the next downstream point, MP15.

Parameter	Measured Sample Data		Allowable	
	Conc. (mg/l)	Load (lbs/day)	LTA Conc. (mg/l)	Load (lbs/day)
Al	1.82	2.8	0.22	0.3
Fe	1.15	1.8	1.15	1.8
Mn	3.31	5.1	0.40	0.6
Acidity	55.20	84.6	3.31	5.1
Alkalinity	4.84	7.4		

	Al (lbs/day)	Fe (lbs/day)	Mn (lbs/day)	Acidity (lbs/day)
Existing Load	2.8	1.8	5.1	84.6
Allowable Load	0.3	1.8	0.6	5.1
Load Reduction	2.4	0.0	4.5	79.5
% Reduction Required	88	0	88	94

TMDL Calculations - Sample Point MP15, Mouth of Penn Run

The TMDL for sample point MP15 consists of a load allocation to all of the area between points MP15, MP14, MP13, MP7 and MP1 (Attachment A). The load allocation for this segment was computed using water-quality sample data collected at point MP15. The average flow of 7.07 MGD, measured at the point, is used for these computations.

This segment is included on the 1996 PA Section 303(d) list for metals impairments from AMD. Sample data at point MP15 shows pH ranging between 5.7 and 6.9; pH is addressed as part of this TMDL.

Parameter	Measured Sample Data		Allowable	
	Conc. (mg/l)	Load (lbs/day)	LTA Conc. (mg/l)	Load (lbs/day)
Al	1.42	83.9	0.30	17.6
Fe	5.55	327.5	0.50	29.5
Mn	2.74	161.4	0.41	24.2
Acidity	20.77	1,224.9	2.49	147.0
Alkalinity	15.00	884.6		

The calculated upstream load reductions for all the loads that enter point MP15 must be accounted for in the calculated reductions at the sample point shown in Table C10. A comparison of measured loads between points MP15, MP14, MP13, MP7 and MP1 shows that there is an increase in loading for all parameters. The total segment load is the sum of the upstream loads and the additional load entering the segment.

Table C10. Calculation of Load Reduction Necessary at Point MP15				
	Al (lbs/day)	Fe (lbs/day)	Mn (lbs/day)	Acidity (lbs/day)
Existing Load	83.9	327.5	161.4	1,224.9
Difference in Existing Load	30.0	234.9	110.4	463.6
Load tracked from upstream	15.1	14.1	7.4	54.9
Total Load tracked between points	45.1	249.0	117.8	518.5
Allowable Load at MP15	17.6	29.5	24.2	147.0
Load Reduction at MP15	27.5	219.5	93.6	371.5
% Reduction Required at MP15	61	88	79	72

Margin of Safety

For this study the margin of safety is applied implicitly. A MOS is implicit because the allowable concentrations and loadings were simulated using Monte Carlo techniques and employing the @Risk software. Other margins of safety used for this TMDL analysis include the following:

- Effluent variability plays a major role in determining the average value that will meet water-quality criteria over the long-term. The value that provides this variability in our analysis is the standard deviation of the dataset. The simulation results are based on this variability and the existing stream conditions (an uncontrolled system). The general assumption can be made that a controlled system (one that is controlling and stabilizing the pollution load) would be less variable than an uncontrolled system. This implicitly builds in a margin of safety.
- An additional MOS is provided because that the calculations were done with a daily Fe average instead of the 30-day average

Seasonal Variation

Seasonal variation is implicitly accounted for in these TMDLs because the data used represents all seasons.

Critical Conditions

The reductions specified in this TMDL apply at all flow conditions. A critical flow condition could not be identified from the data used for this analysis.

Attachment D

Excerpts Justifying Changes Between the 1996, 1998, 2002 and 2004 Section 303(d) Lists

The following are excerpts from the Pennsylvania DEP Section 303(d) narratives that justify changes in listings between the 1996, 1998, and 2002 list. The Section 303(d) listing process has undergone an evolution in Pennsylvania since the development of the 1996 list.

In the 1996 Section 303(d) narrative, strategies were outlined for changes to the listing process. Suggestions included, but were not limited to, a migration to a Global Information System (GIS), improved monitoring and assessment, and greater public input.

The migration to a GIS was implemented prior to the development of the 1998 Section 303(d) list. As a result of additional sampling and the migration to the GIS some of the information appearing on the 1996 list differed from the 1998 list. Most common changes included:

1. mileage differences due to recalculation of segment length by the GIS;
2. slight changes in source(s)/cause(s) due to new EPA codes;
3. changes to source(s)/cause(s), and/or miles due to revised assessments;
4. corrections of misnamed streams or streams placed in inappropriate SWP subbasins; and
5. unnamed tributaries no longer identified as such and placed under the named watershed listing.

Prior to 1998, segment lengths were computed using a map wheel and calculator. The segment lengths listed on the 1998 Section 303(d) list were calculated automatically by the GIS (ArcInfo) using a constant projection and map units (meters) for each watershed. Segment lengths originally calculated by using a map wheel and those calculated by the GIS did not always match closely. This was the case even when physical identifiers (e.g., tributary confluence and road crossings) matching the original segment descriptions were used to define segments on digital quad maps. This occurred to some extent with all segments, but was most noticeable in segments with the greatest potential for human errors using a map wheel for calculating the original segment lengths (e.g., long stream segments or entire basins).

Attachment E

Water Quality Data Used In TMDL Calculations

Station	Date	Flow gpm	pH	Alkalinity mg/L	Acidity mg/L	Iron mg/L	Manganese mg/L	Aluminum mg/L	Sulfate mg/L
MP15	5/31/2001	N/A	6.0	16.8	0.0	7.150	3.070	0.991	270.1
	6/29/2001	N/A	5.8	10.8	55.4	10.300	4.030	1.160	307.7
Latitude:	6/19/2002	6849	5.8	11.8	34.0	2.910	2.360	2.770	144.4
40.6375	7/22/2002	1288	5.7	8.6	56.0	8.980	4.530	1.480	460.0
Longitude:	5/22/2003	5853	6.5	21.2	0.0	2.820	1.350	0.822	92.7
-79.03639	6/20/2003	4342	6.8	18.2	0.0	3.580	1.890	1.030	162.2
Mouth of Penn Run	8/8/2003	6220	6.9	17.6	0.0	3.140	1.930	1.710	149.4
	AVG	4910.40	6.21	15.00	20.77	5.55	2.74	1.42	226.64
	ST DEV	2225.23	0.51	4.61	26.90	3.19	1.19	0.67	127.63
MP14	6/19/2002	248	4.9	10.6	47.2	1.18	2.36	1.31	155.3
	7/22/2002	67	4.0	1.4	66.0	1.11	6.09	3.89	541.8
Latitude:	5/22/2003	103.2	4.1	3.8	58.4	<.3	2.47	1.16	169.3
40.63917	6/20/2003	58.3	4.1	2.6	53.4	<.3	3.09	1.59	229.4
Longitude:	8/8/2003	161.7	4.6	5.8	51	<.3	2.54	1.13	151.5
-79.01833	AVG	127.64	4.34	4.84	55.20	1.15	3.31	1.82	249.46
Mouth of Unnamed Tributary 44278	ST DEV	78.63	0.39	3.61	7.28	0.05	1.58	1.17	166.40
MP13	5/31/2001	N/A	3.7	0.0	64.0	15.000	7.710	2.620	242.6
	6/29/2001	N/A	3.7	0.0	112.0	20.300	10.200	2.730	337.8
Latitude:	6/19/2002	373	3.6	0.0	97.2	8.830	8.220	8.640	200.3
40.63472	7/22/2002	22	3.2	0.0	236.0	27.600	29.000	10.500	500.1
Longitude:	5/22/2003	334.4	4.9	6.6	58.4	3.810	2.760	1.320	80.5
-79.01333	6/20/2003	67.9	4.0	1.2	72.6	8.790	5.830	2.240	189.2
Mouth of Unnamed Tributary 44280	8/8/2003	179.5	4.3	4.6	58.4	7.640	5.080	2.400	150.0
	AVG	195.36	3.91	1.77	99.80	13.14	9.83	4.35	242.93
	ST DEV	156.08	0.55	2.71	63.45	8.35	8.79	3.64	138.36

Station	Date	Flow gpm	pH	Alkalinity mg/L	Acidity mg/L	Iron mg/L	Manganese mg/L	Aluminum mg/L	Sulfate mg/L
MP7	5/31/2001	516	5.9	18.2	12.4	7.620	2.140	1.700	273.0
	6/28/2001	178	5.9	11.8	50.2	9.270	2.170	1.160	312.1
Latitude:	6/19/2002	1639	4.5	7.6	72.2	2.630	3.370	7.700	245.8
40.63889	7/22/2002	147	4.9	7.6	62.0	10.100	2.710	2.340	394.2
Longitude:	5/22/2003	920	6.3	17	39.4	2.470	1.260	1.500	136.1
-79.00944	6/20/2003	687.8	5.9	13.2	36.8	2.980	1.570	2.060	192.6
Mouth of Unnamed Tributary 44281	8/8/2003	1598	4.9	8.2	44.6	2.310	2.230	3.870	216.9
	AVG	812.26	5.47	11.94	45.37	5.34	2.21	2.90	252.96
	ST DEV	613.81	0.69	4.44	19.22	3.50	0.70	2.29	84.16
MP1	5/31/2001	485	7.2	88.00	0.0	0.3	0.078	<0.5	80.5
	6/28/2001	414	7.8	106.00	0.0	0.3	<0.05	<5	65.6
Latitude:	6/19/2002	2547	6.8	58.00	0.0	1.2	0.113	0.741	61.7
40.63806	7/22/2002	146	8.0	140.00	0.0	0.3	0.065	<0.5	232.9
Longitude:	5/22/2003	2893	7.0	41.20	0.0	0.392	0.07	<0.5	34.5
-79.00500	6/20/2003	1165	7.8	64.00	0.0	0.399	0.068	<0.5	40.9
Penn Run upstream of discharges	8/8/2003	2280	7.8	58.40	0.0	0.392	0.079	<0.5	34.8
	AVG	1418.57	7.49	79.37	0.00	0.47	0.08	0.74	78.70
	ST DEV	1136.79	0.47	34.28	0.00	0.33	0.02	NA	70.18

SULFATE DATA

Site Name	Date	Sulfates (mg/L)	Flow gpm	
KBLTL3	5/12/1999	180.00		
	11/5/2002	149.70		Drainage Area (sq mi) = 55
	7/20/2002	221.00		Flow = Drainage Area * Unit Area Flow
	4/25/2002	149.00		Flow (MGD) = 39.8
	2/26/2002	131.00		
	10/31/2003	97.90		
AVG		154.77		
ST DEV		42.15		
KBLTL2	10/24/2003	81.60		Drainage Area (sq mi) = 170
	8/3/2003	87.60		Unit Area Flow = Flow / Drainage Area
	4/25/2003	89.90		Unit Area Flow (MGD/sq. mi)= 0.72
	10/25/2002	189.20		
	7/21/2002	92.60	150	
	4/19/2002	78.40		
	2/18/2002	94.70	218	
	7/12/2001		67231	
	4/26/2001	80.20	280577	
	1/23/2001		115189	
	10/10/2000		46384	
	4/12/2000	95.00	172473	
	1/12/2000	95.00	708	
	5/25/1999	87.00		
AVG		97.4	85,366	
ST DEV		31.0	100,080	
		Flow (MGD) =	122.9	

Attachment F

Comment and Response

No comments received.